

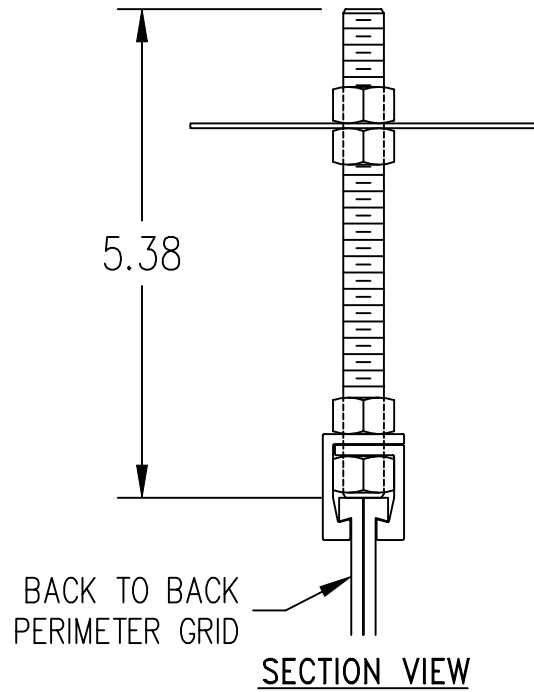

LEVEL	ITEM	* PART NO. =Stocked	QTY. TOTAL	DESCRIPTION	QTY. ONE	Weld	Paint	DWG. NO.
	1	27-00114		FILTER HOLD DOWN TYPE A PERIMETER	1			
	2							
	3	125-50-24		NUT .5 X NC LH HEX PLTD	4			
	4	175-72-83		ATR .5 X 5.375 NC LH GR2 PLT	1			
	5	27-00020		GRID HANGER 2.6 LH X 1.00"	1			27-00-20
	6	27-00021		GRID HANGER 2.6 RH X 1.00"	1			27-00-20
	7	175-72-85		PACMAN FILTER HOLD DOWN PLATE	1			27-01-15

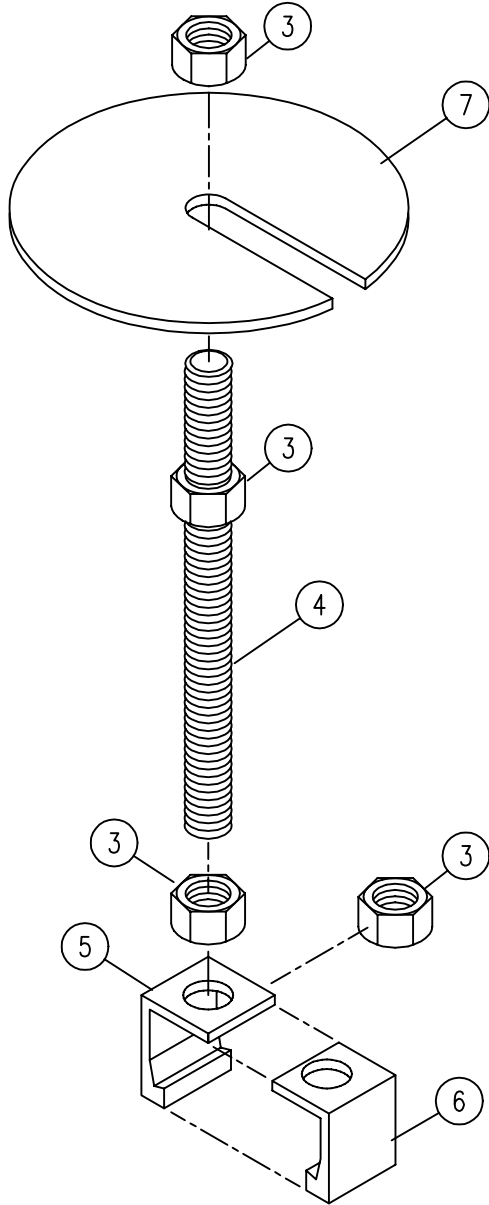

**TYPE A**  
**REQUIRED**

FILE NAME: 27-01-13.dwg				TOLERANCES UNLESS OTHERWISE SPECIFIED		DRAWN BY: JAC		 11241 S. E. HIGHWAY 212 CLACKAMAS OR 97015 Phone (503) 557-4500 Fax (503) 557-4501	
REV.	DATE	BY	DESCRIPTION	FRACTIONS : ±1/32		ISSUED ON: 02/10/00		TITLE:	
1	10/01	WR	UPDATED BOM	0.0 : ±0.1		CHECKED BY:		CLEAN-TRAK 2.6 FILTER HOLD DOWN AT GRID PERIMETER	
				0.00 : ±0.03		SCALE:		SIZE: A DRAWING NO.: 27-01-13	
THIS DRAWING IS THE PROPERTY OF CLEANPAK AND CAN NOT BE REPRODUCED IN WHOLE OR IN PART, NOR DELIVERED TO OTHERS WITHOUT THE EXPRESS WRITTEN PERMISSION OF CLEANPAK.				0.0000 : GIVEN		JOB NO.:		SHEET OF	
				ANGLES : ±0.5°					