

LEVEL	ITEM	* PART NO. =Stocked	QTY. TOTAL	DESCRIPTION	QTY. ONE	Weld Point	DWG. NO.
	0	27-00111		GRID HANGER TYPE 2A MIDSPAN	1		
	1	125-50-24		NUT .5 X NC LH HEX PLTD	4		
	2	175-72-82		ATR .50 X 8 NC LH GR2 PLATED	1		
	3	27-00022		GRID HANGER 2.6 LH X 2.50"	1		27-00-21
	4	27-00023		GRID HANGER 2.6 RH X 2.50"	1		27-00-21
	5	175-72-85		PACMAN FILTER HOLD DOWN PLATE	1		27-01-15

1

NOTE:
 * ASSEMBLY SHOULD BE TIGHTENED TO "SNUG TIGHT" AS DEFINED BY AISC.
 * CAUTION SHOULD BE TAKEN NOT TO OVER-TORQUE THE ASSEMBLY.
 * OVER-TORQUING THE ASSEMBLY CAN RESULT IN DEFORMATION OF THE ALUMINUM HANGERS.
 * HANGERS THAT ARE DEFORMED SHOULD NOT BE USED.

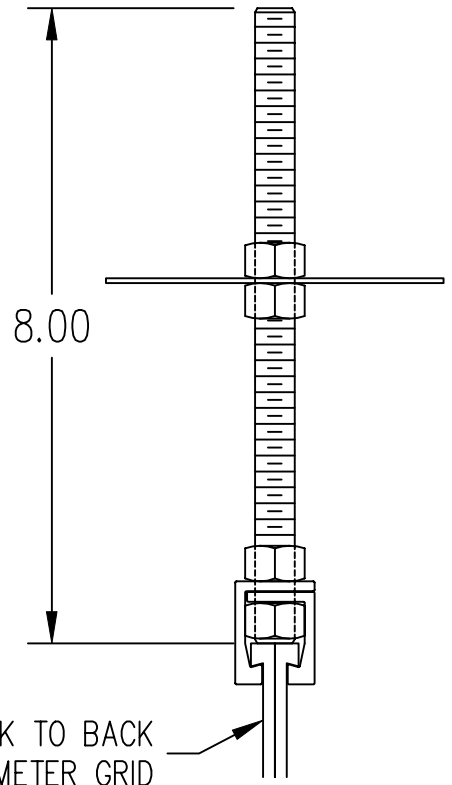
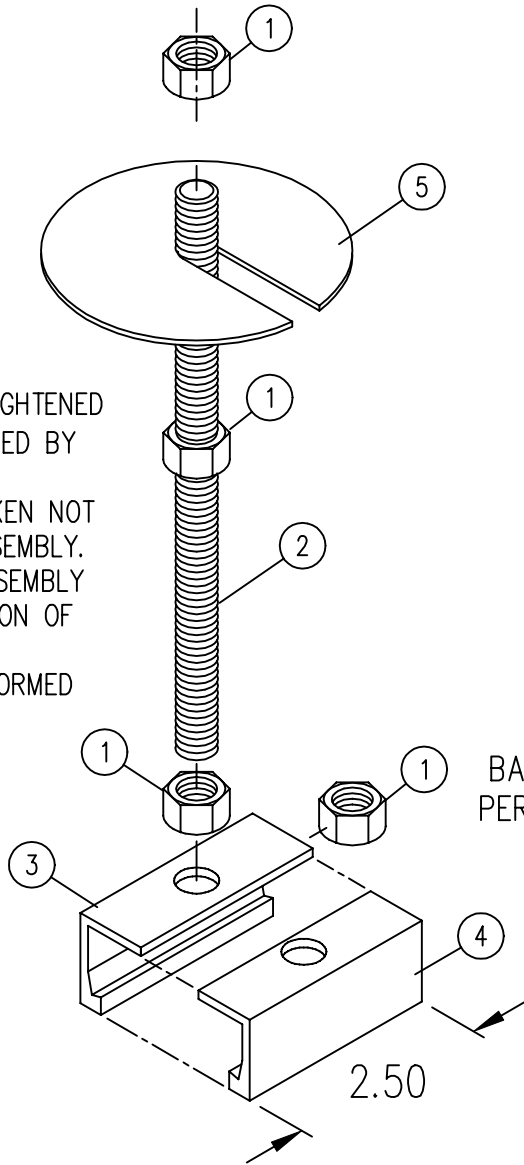

SECTION VIEW

1

ALLOWABLE LOAD RATING: 3.1 KIPS

TYPE 2A
 REQUIRED

FILE NAME: 27-01-10.dwg				TOLERANCES UNLESS OTHERWISE SPECIFIED		DRAWN BY: Jeffc		 11241 S. E. HIGHWAY 212 CLACKAMAS OR 97015 Phone (503) 557-4500 Fax (503) 557-4501	
REV.	DATE	BY	DESCRIPTION	FRACTIONS : ±1/32		ISSUED ON: 2/10/00		TITLE: CLEAN-TRAK 2.6 GRID SUSPENSION & FILTER HOLD DOWN AT PERIMETER MIDSPAN	
1	10/01	WR	ADDED NOTES & UPDATED BOM	0.0 : ±0.1		CHECKED BY:		DRAWING NO.: 27-01-10	
				0.00 : ±0.03		SCALE:		SIZE: A	
				0.000 : ±0.010		JOB NO.:		SHEET OF	
				0.0000 : GIVEN					
				ANGLES : ±0.5°					
THIS DRAWING IS THE PROPERTY OF CLEANPAK AND CAN NOT BE REPRODUCED IN WHOLE OR IN PART, NOR DELIVERED TO OTHERS WITHOUT THE EXPRESS WRITTEN PERMISSION OF CLEANPAK.									