

LEVEL	ITEM	* PART NO. =Stocked	QTY. TOTAL	DESCRIPTION	QTY. ONE	Weld Point	DWG. NO.
	1	27-00062		GRID HANGER TYPE 4 CORNER	1		
	2						
	3						
	4	175-72-81		ATR .50 X 7 NC LH GR2 PLAIN	1	*	
	5	27-00024		GRID HANGER 2.6 LH X 1.38"	2		27-00-22
	6	27-00025		GRID HANGER 2.6 RH X 1.38"	2		27-00-22
	7	27-00053		BRKT GRID 2.25 X 2.25 X .50 PL	1	*	27-01-16
	8	131-63-76		BOLT .5 X 2.5 NC SOCSET ELECTRO	2		
	9	125-00-55		NUT .5 X NC FIN HX ZNC	4		
	10	125-50-24		NUT .5 X NC LH HEX PLTD	2	*	

NOTE:
ELECTROLESS NICKLE
PARTS AND ASSEMBLE.
TACK WELD NUT TO
BOTTOM OF ROD.

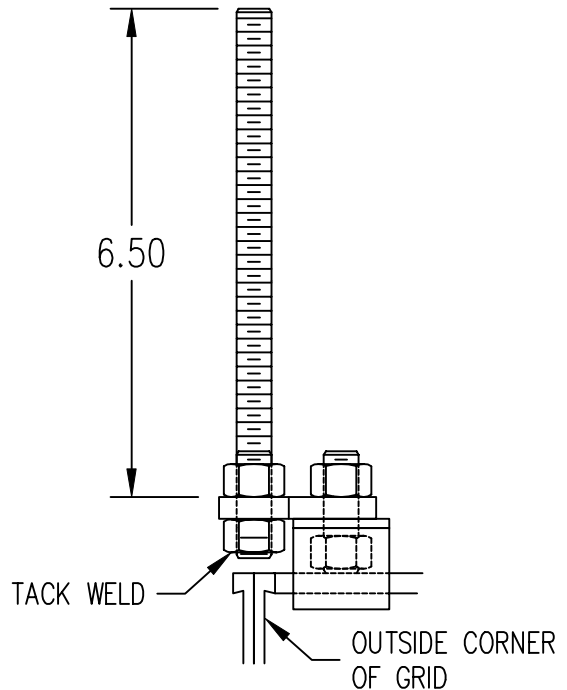

NOTE:
* ASSEMBLY SHOULD BE TIGHTENED TO "SNUG TIGHT" AS
DEFINED BY AISC.
* CAUTION SHOULD BE TAKEN NOT TO OVER-TORQUE THE
ASSEMBLY.
* OVER-TORQUING THE ASSEMBLY CAN RESULT IN
DEFORMATION OF THE ALUMINUM HANGERS.
* HANGERS THAT ARE DEFORMED SHOULD NOT BE USED.

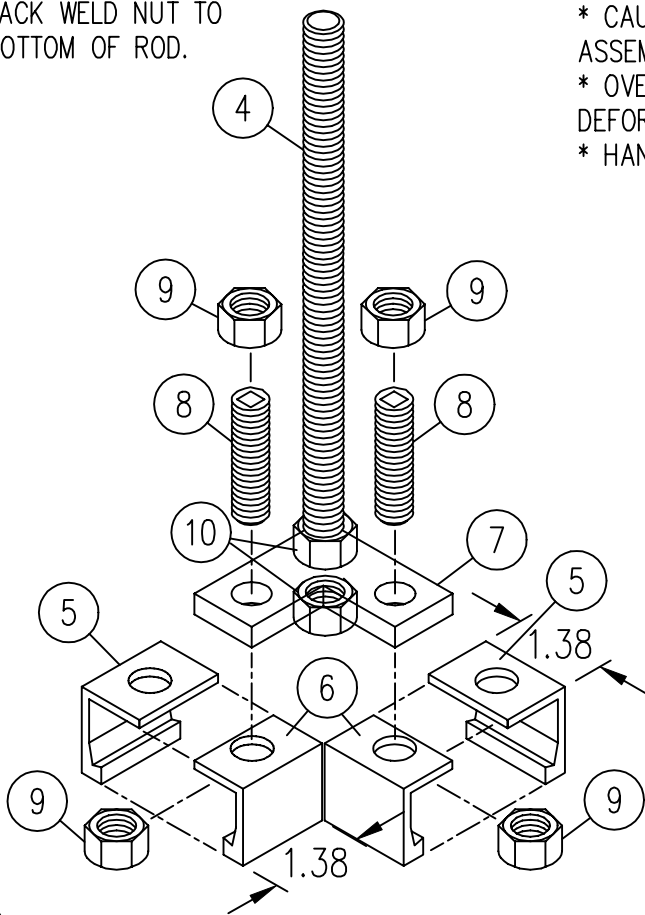

SECTION VIEW

TYPE 4
REQUIRED



ALLOWABLE LOAD RATING: 1.2 KIPS

FILE NAME: 27-01-08.dwg			TOLERANCES UNLESS OTHERWISE SPECIFIED	DRAWN BY: Jeffc	 11241 S. E. HIGHWAY 212 CLACKAMAS OR 97015 Phone (503) 557-4500 Fax (503) 557-4501
REV.	DATE	BY	DESCRIPTION	ISSUED ON: 2/10/00	
2	10/01	WR	UPDATED BOM	CHECKED BY:	TITLE: GRID HANGER TYPE 4 CORNER CLEAN-TRAK 2.6 GRID SUSPENSION AT OUTSIDE PERIMETER CORNER
1	08/06	daveb	ADDED NOTE	SCALE:	
THIS DRAWING IS THE PROPERTY OF CLEANPAK AND CAN NOT BE REPRODUCED IN WHOLE OR IN PART, NOR DELIVERED TO OTHERS WITHOUT THE EXPRESS WRITTEN PERMISSION OF CLEANPAK.			FRACTIONS : ±1/32 0.0 : ±0.1 0.00 : ±0.03 0.000 : ±0.010 0.0000 : GIVEN ANGLES : ±0.5°	SIZE: A	DRAWING NO.: 27-01-08
				JOB NO.:	SHEET OF