

LEVEL	ITEM	* PART NO. =Stocked	QTY. TOTAL	DESCRIPTION	QTY. ONE	Weld	Paint	DWG. NO.
	1	27-00060		GRID HANGER TYPE 2 MIDSPAN	1			
	2							
	3	125-50-24		NUT .5 X NC LH HEX PLTD	2			
	4	175-72-82		ATR .50 X 8 NC LH GR2 PLATED	1			
	5	27-00022		GRID HANGER 2.6 LH X 2.50"	1			27-00-21
	6	27-00023		GRID HANGER 2.6 RH X 2.50"	1			27-00-21

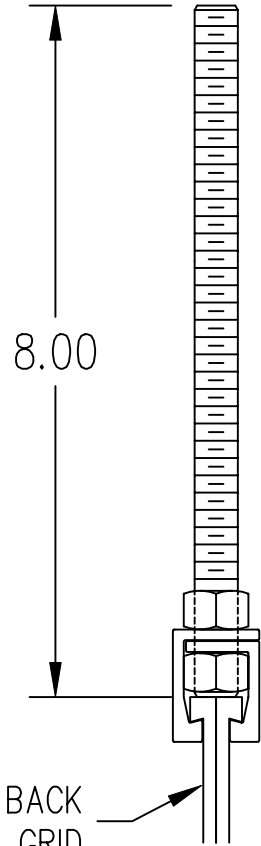

NOTE:

- * ASSEMBLY SHOULD BE TIGHTENED TO "SNUG TIGHT" AS DEFINED BY AISC.
- * CAUTION SHOULD BE TAKEN NOT TO OVER-TORQUE THE ASSEMBLY.
- * OVER-TORQUING THE ASSEMBLY CAN RESULT IN DEFORMATION OF THE ALUMINUM HANGERS.
- * HANGERS THAT ARE DEFORMED SHOULD NOT BE USED.

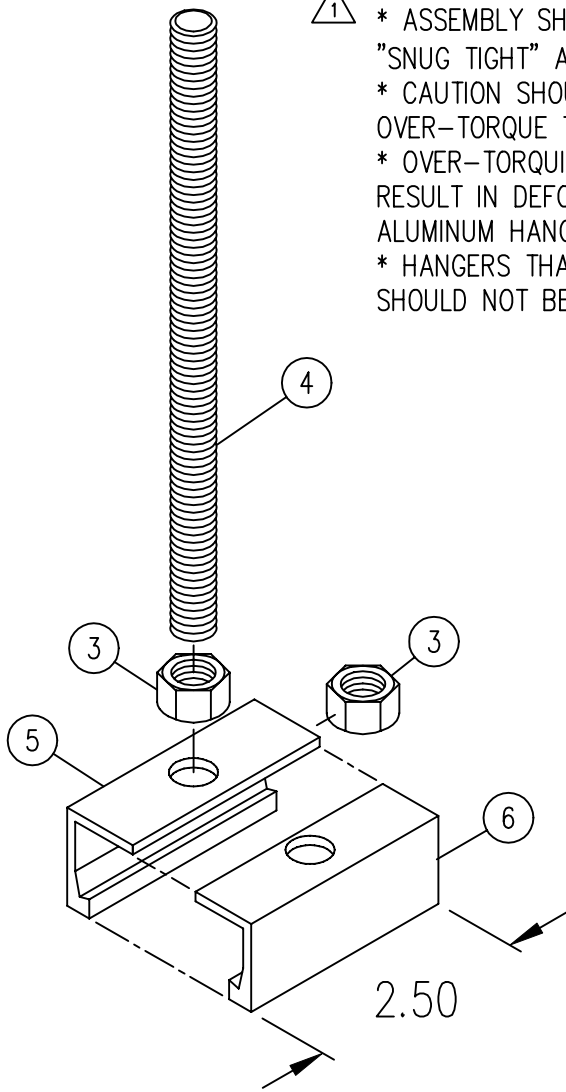

SECTION VIEW



ALLOWABLE LOAD RATING: 3.1 KIPS

TYPE 2
REQUIRED

FILE NAME: 27-01-06.dwg				TOLERANCES UNLESS OTHERWISE SPECIFIED		DRAWN BY: Jeffc		 11241 S. E. HIGHWAY 212 CLACKAMAS OR 97015 Phone (503) 557-4500 Fax (503) 557-4501	
REV.	DATE	BY	DESCRIPTION	FRACTIONS : ±1/32		ISSUED ON: 2/10/00		TITLE: GRID HANGER TYPE 2 MIDSPAN CLEAN-TRAK 2.6 GRID SUSPENSION AT PERIMETER MIDSPAN	
2	10/01	WR	UPDATED BOM	0.0 : ±0.1		CHECKED BY:			
1	08/06	daveb	ADDED NOTES	0.00 : ±0.03		SCALE:			
THIS DRAWING IS THE PROPERTY OF CLEANPAK AND CAN NOT BE REPRODUCED IN WHOLE OR IN PART, NOR DELIVERED TO OTHERS WITHOUT THE EXPRESS WRITTEN PERMISSION OF CLEANPAK.				0.000 : ±0.010		SIZE: A		DRAWING NO.: 27-01-06	
				0.0000 : GIVEN		JOB NO.:		SHEET OF	
				ANGLES : ±0.5°					